



## Teca Vino

Model Reg. n. TO 2011/29 • Design Reg. n. TO 2009/31

La Teca si presenta sobria ma elegante, volutamente minimalista ed essenziale. Le bottiglie sono parte della scenografia dove la particolare esposizione in orizzontale ne esalta valore e bellezza. È un oggetto dal design inconfondibile destinato a rendere speciale ogni ambiente in cui è inserito.

*Teca is sober but elegant, deliberately minimal and essential. The bottles are part of a scene where the trademark horizontal display enhances value and beauty. It is an object with a unique design intended to give a unique feel to any location.*

*Teca est sobre mais élégante, délibérément minimaliste et essentielle. Les bouteilles font partie de la scène où la disposition horizontale accroît la valeur et la beauté. Il est un objet avec un design unique destiné à rendre unique chaque ambiente dans lequel elle est insérée.*

TECA VINO

Wine cooling units · Modules réfrigérés pour vin



°C  
+4 / +18

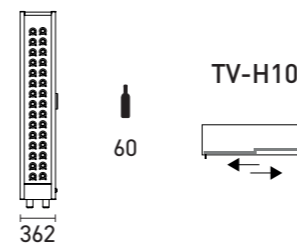

mm 860 x 362 x 1852

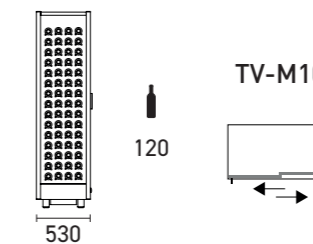

mm 860 x 530 x 1893

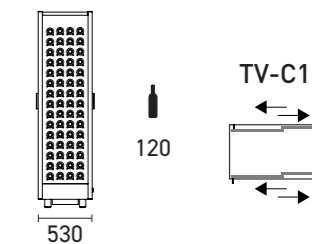

mm 860 x 530 x 1893



°C  
+4 / +18

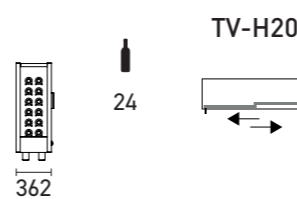

mm 860 x 362 x 897

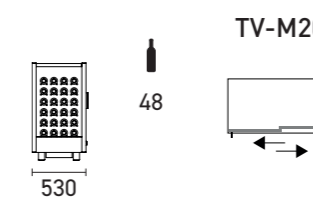

mm 860 x 530 x 938

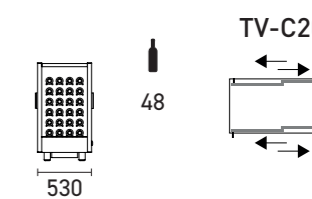

mm 860 x 530 x 938

COLORS (Pag. 170)





°C  
+4 / +18

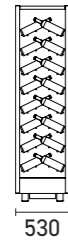

112

TV-M12

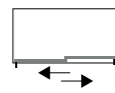

mm 860 x 530 x 1893



112

TV-C12

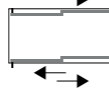

mm 860 x 530 x 1893



°C  
+4 / +18



128

TV-M13

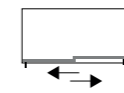

mm 860 x 530 x 1893



128

TV-C13

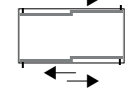

mm 860 x 530 x 1893



°C  
+4 / +18

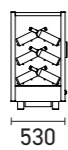

42

TV-M22

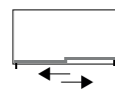

mm 860 x 530 x 938



42

TV-C22

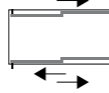

mm 860 x 530 x 938



°C  
+4 / +18



64

TV-M23

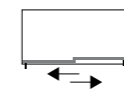

mm 860 x 530 x 938



64

TV-C23

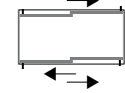

mm 860 x 530 x 938

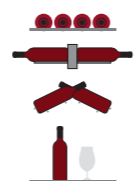

Allestimento interno personalizzabile  
 Custom internal layout  
 Aménagement intérieur personnalisable

°C  
 +4 / +18

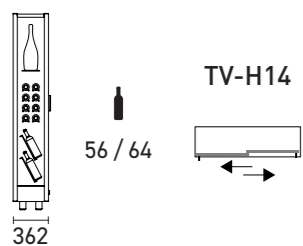

mm 860 x 362 x 1852

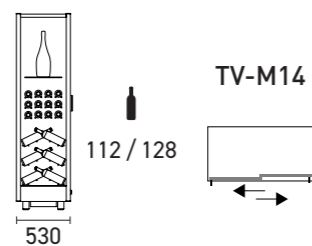

mm 860 x 530 x 1893

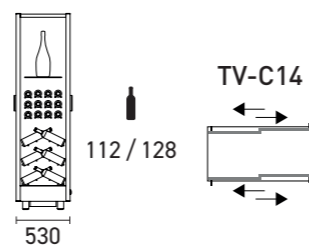

mm 860 x 530 x 1893

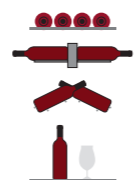

Allestimento interno personalizzabile  
 Custom internal layout  
 Aménagement intérieur personnalisable

°C  
 +4 / +18

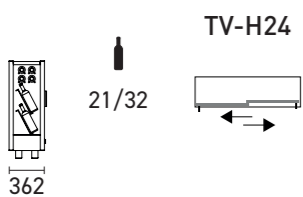

mm 860 x 362 x 897

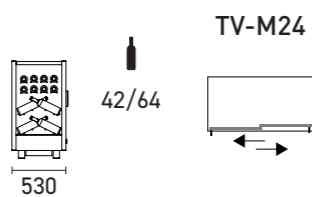

mm 860 x 530 x 938

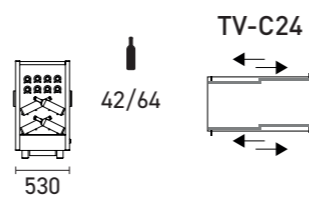

mm 860 x 530 x 938



Food



## Teca B

*Versione ad incasso della vetrina Teca.*

La Teca B è semplice da installare in nicchie o passaggi inutilizzati. La cornice è applicata con sistema ad incastro per cui facilmente sostituibile per qualsiasi esigenza tecnica o commerciale.

*Built-in version of the Teca model.*

Teca B is easy to install in recesses or unused spaces. The frame is mounted with a snap-on system, making it easy to replace for any technical or commercial need.

*Version encastrée de la vitrine Teca.*

Teca B est facile à installer dans des niches ou des passages inutilisés. Le cadre est appliqué avec un système d'emboîture et peut être facilement remplacé pour n'importe quel besoin technique ou commercial.

VINO  
Wine · Vin



°C  
+4 / +18

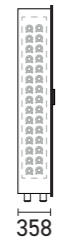

mm 880 x 358 x 1862

TBV-H10

60

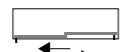

mm 880 x 530 x 1901

TBV-M10

120



VINO  
Wine · Vin



°C  
+4 / +18



mm 880 x 530 x 1901

TBV-M13

128



°C  
+4 / +18



mm 880 x 530 x 1901

TBV-M12

112



°C  
+4 / +18



mm 880 x 358 x 1862

TBV-H14

56/64

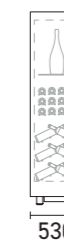

mm 880 x 530 x 1901

TBV-M14

112/128

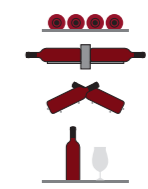

Allestimento interno personalizzabile  
Custom internal layout  
Aménagement intérieur personnalisable



# Teca M

MODULAR  
MAGNETIC

Sistema modulare. Unire più moduli mantenendo l'armonia di un manufatto unico è la soluzione per realizzare un'esposizione ricercata anche in ambienti con spazi ridotti. La vasta gamma di cover magnetiche in collezione consente una semplice personalizzazione.

*Modular system. Joining modules together while keeping the harmony of a single piece is the solution to create an elegant display even in rooms with reduced space. The broad range of available magnetic covers from our collection makes for easy customization.*

*Système modulaire. La combinaison de plusieurs modules tout en maintenant l'harmonie d'un produit unique est la solution pour obtenir une exposition recherchée même dans des ambiances avec espace réduit. La large gamme de Cover magnétiques de la collection permet une personnalisation facile.*

MODULI REFRIGERATI PER VINO

Wine cooling units · Modules réfrigérés pour vin



°C  
+4 / +18

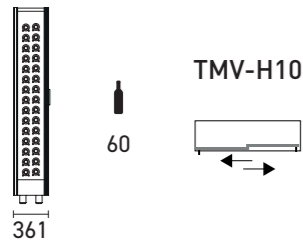

mm 860 x 361 x 1850

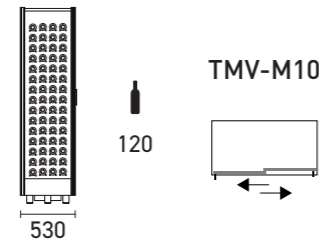

mm 860 x 530 x 1891

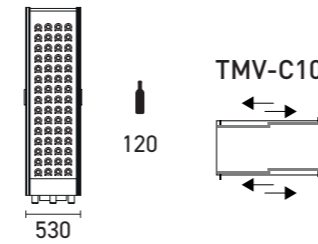

mm 860 x 530 x 1891



°C  
+4 / +18

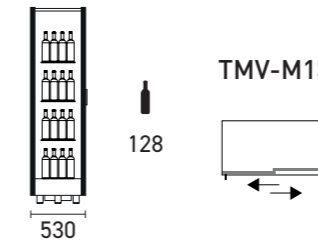

mm 860 x 530 x 1891

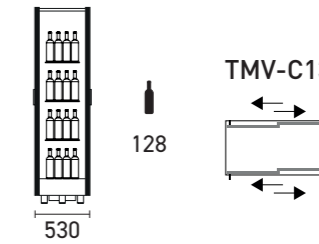

mm 860 x 530 x 1891



°C  
+4 / +18

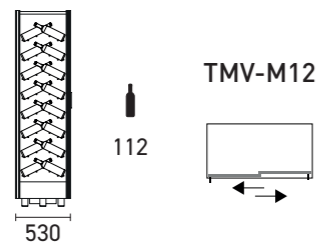

mm 860 x 530 x 1891

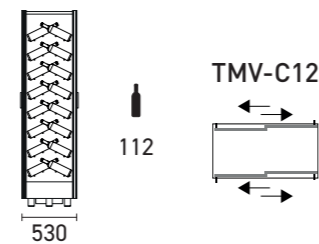

mm 860 x 530 x 1891



°C  
+4 / +18

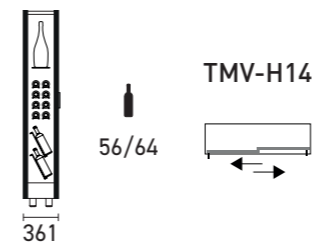

mm 860 x 361 x 1850

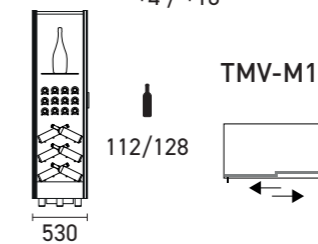

mm 860 x 530 x 1891

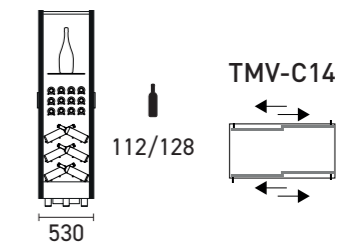

mm 860 x 530 x 1891

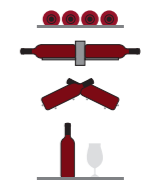

Allestimento interno personalizzabile  
Custom internal layout  
Aménagement intérieur personnalisable



Teca M  
MODULAR  
MAGNETIC



°C  
+4 / +18



°C  
+4 / +18

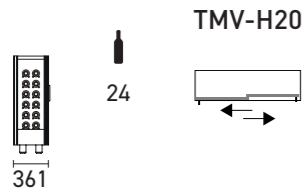

mm 860 x 361 x 895

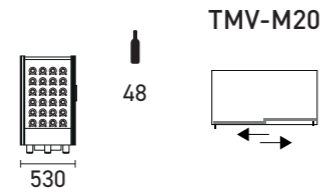

mm 860 x 530 x 936

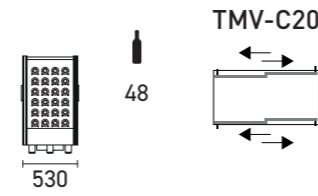

mm 860 x 530 x 936



mm 860 x 530 x 936

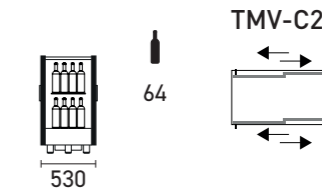

mm 860 x 530 x 936



°C  
+4 / +18



°C  
+4 / +18

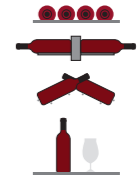

Allestimento interno personalizzabile  
Custom internal layout  
Aménagement intérieur personnalisable

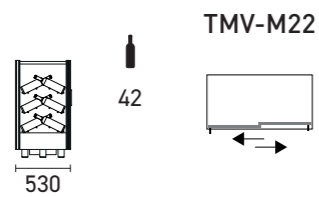

mm 860 x 530 x 936

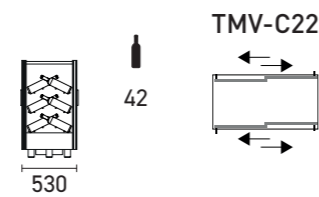

mm 860 x 530 x 936

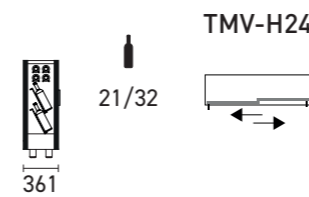

mm 860 x 361 x 895

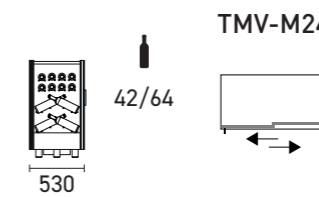

mm 860 x 530 x 936

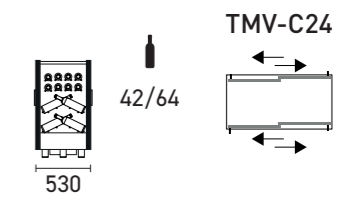

mm 860 x 530 x 936



## Parete Vino

Model Reg. n. TO 2011/29 • Design Reg. n. TO 2012/41

Sistema modulare per l'esposizione, conservazione e servizio del vino. L'inserimento di uno o più moduli gastronomia, salumeria o cioccolato consente di realizzare una pratica, elegante e ben distinta area dedicata esclusivamente all'esposizione enogastronomica.

*Modular system for displaying, storing and serving your wine. Adding one or more cold dishes, cured meats/cheese, or chocolate modules makes for a practical, elegant, and remarkable area for your wine and food display.*

*Système modulaire pour l'exposition, la conservation et le service de vin. L'ajout d'un ou plusieurs modules gastronomie, salaisons ou chocolat permet de réaliser un espace pratique, élégant et bien séparé réservé exclusivement à l'exposition de produits gastronomiques et oenologiques.*

MODULI REFRIGERATI PER VINO

Wine cooling units · Modules réfrigérés pour vin



Parete Vino

Composizione da appoggio con profondità ridotta composta da PH-VAR10 e PH-VAR14. Cornice lineare e pannelli laterali L22 (wengé loft).

Wall-back composition with reduced depth, made with PH-VAR10 and PH-VAR14 modules.

Linear frame and side panes in L22 finish (wengé loft).

Composition appuyée avec profondeur réduite composé un module PH-VAR10 et PH-VAR14.

Cadre linéaire et panneaux latéraux L22 (finition wengue loft).



°C  
+4 / +18



60

PH-VAR10



mm 900 x 350 x 1857



120

PM-VAR10



mm 900 x 510 x 1898

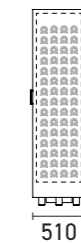

120

PC-VAR10



mm 900 x 510 x 1898



°C  
+4 / +18



112

PM-VAR12



mm 900 x 510 x 1898



112

PC-VAR12



mm 900 x 510 x 1898

MODULI REFRIGERATI PER VINO

Wine cooling units · Modules réfrigérés pour vin



Parete Vino

Composizione da appoggio composta da PM-VAR10 ai lati, PM-VAR12 centrale, moduli superiori PM-VBR10.

Cornice lineare e pannelli laterali RAL9005 (nero).

Wall-back composition made with PM-VAR12 between two PM-VAR10 and upper PM-VBR10 modules.

Linear frame and side panes in RAL9005 finish (black).

Composition appuyée composée par deux éléments PM-VAR10 sur les côtés, un PM-VAR12 central, modules supérieurs PM-VBR10.

Cadre linéaire et panneaux latéraux RAL9005 (noir).



°C  
+4 / +18



PM-VAR13

128



mm 900 x 510 x 1898



PC-VAR13

128

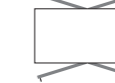

mm 900 x 510 x 1898

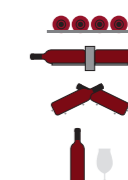

Allestimento interno personalizzabile  
Custom internal layout  
Aménagement intérieur personnalisable

°C  
+4 / +18



PH-VAR14

56/64



mm 900 x 350 x 1857



PM-VAR14

112/128



mm 900 x 510 x 1898

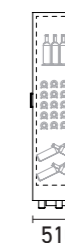

PC-VAR14

112/128



mm 900 x 510 x 1898

MODULI NEUTRI

Neutral modules • Modules neutres

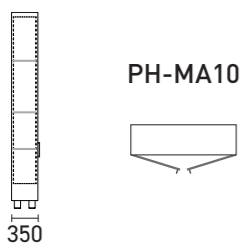

PH-MA10

mm 900 x 350 x 1880

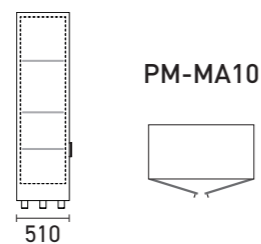

PM-MA10

mm 900 x 510 x 1898

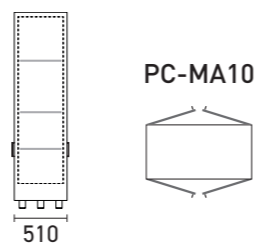

PC-MA10

mm 900 x 510 x 1898

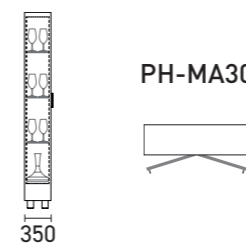

PH-MA30

mm 900 x 350 x 1880

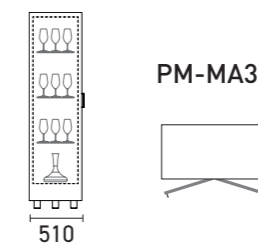

PM-MA30

mm 900 x 510 x 1898

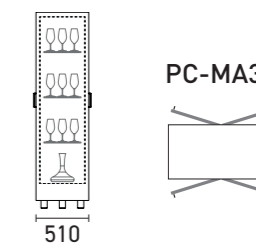

PC-MA30

mm 900 x 510 x 1898

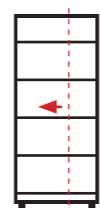

Modulo realizzabile su misura da cm 20 a cm 90  
 Custom made unit from cm. 20 up to cm. 90  
 Module sur mesure de cm. 20 jusqu'à cm. 90

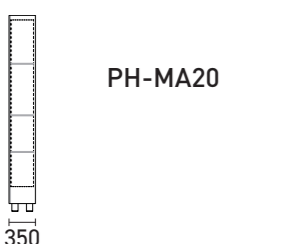

PH-MA20

mm 900 x 350 x 1880

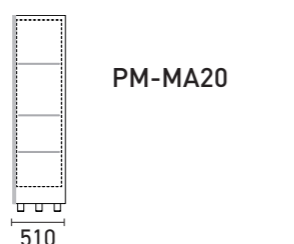

PM-MA20

mm 900 x 510 x 1898

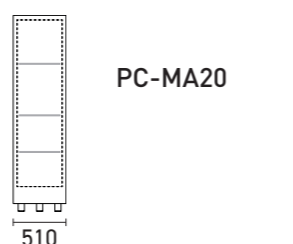

PC-MA20

mm 900 x 510 x 1898

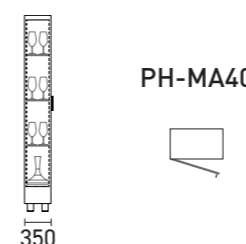

PH-MA40

mm 486 x 350 x 1880

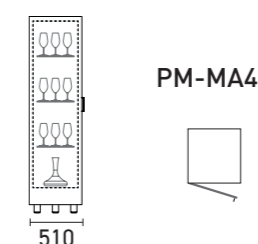

PM-MA40

mm 486 x 510 x 1898

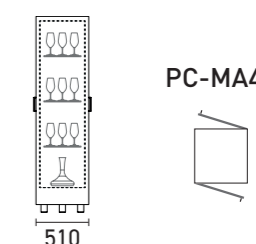

PC-MA40

mm 486 x 510 x 1898

MODULI REFRIGERATI PER VINO - B

Wine cooling units · Modules réfrigérés pour vin



Modulo "B"

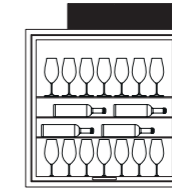

• Vista posteriore  
Rear view  
Vue postérieure

PC-VBR10

°C  
+14 / +16

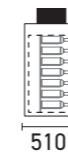

64

PM-VBR10



64 +

PC-VBR10

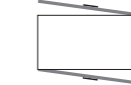

510

510

mm 900 x 510 x 1050

mm 900 x 510 x 1050

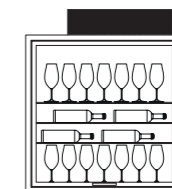

• Vista posteriore  
Rear view  
Vue postérieure

PC-VBR13

°C  
+14 / +16



80

PM-VBR13



80 +

PC-VBR13



510

510

mm 900 x 510 x 1050

mm 900 x 510 x 1050

**MODULI NEUTRI - B**  
Neutral modules • Modules neutres

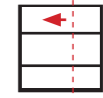

Modulo realizzabile su misura da cm 20 a cm 90  
Custom made unit from cm. 20 up to cm. 90  
Module sur mesure de cm. 20 jusqu'à cm. 90

PH-MB30

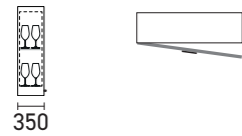

mm 900 x 350 x 900

PM-MB30

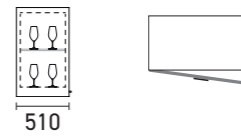

mm 900 x 510 x 900

PC-MB30

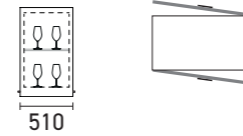

mm 900 x 510 x 900

PH-MB20

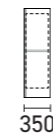

mm 900 x 350 x 900

PM-MB20



mm 900 x 510 x 900

PC-MB20



mm 900 x 510 x 900



PH-MB40



mm 486 x 350 x 900

PM-MB40

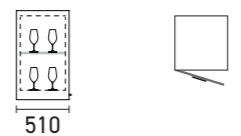

mm 486 x 510 x 900

PC-MB40

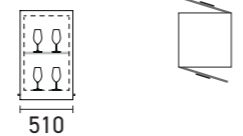

mm 486 x 510 x 900





## Modulo "D"

Con l'utilizzo del modulo "D" è possibile realizzare sia una soluzione tipo banco, utilizzando il rivestimento FIT, sia la soluzione a pensile, utilizzando le cornici.

Per realizzare una elegante esposizione enogastronomica, in aggiunta ai moduli per il vino, si possono inserire moduli neutri, salumeria e gastronomia.

*With type "D" modules it is possible to create either a counter-like solution using our FIT cladding, or a suspended composition using our frames.*

*To realize an elegant enogastronomic display in addition to bottle units it is possible to add also neutral units, delicatessen and gastronomy ones.*

*Le module « D » est employable soit pour réaliser un comptoir avec une finition de revêtement FIT, soit pour une installation suspendue encastré finie par une cadre.*

*Pour réaliser une exposition enogastronomique élégante on peut insérer de modules neutres ou pour charcuterie et gastronomie.*



°C  
+4 / +18



°C  
+4 / +18

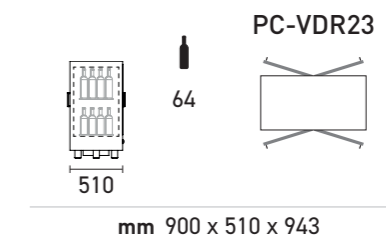
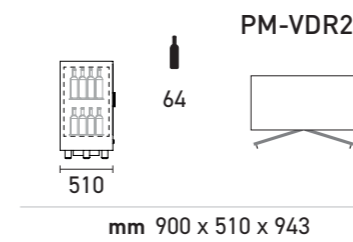
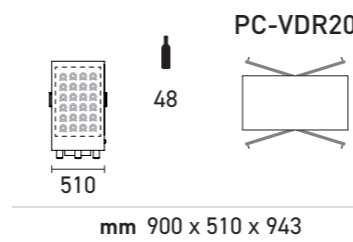
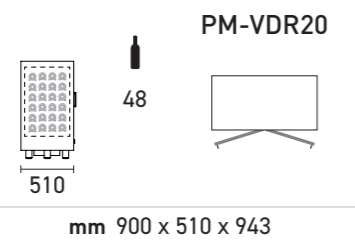
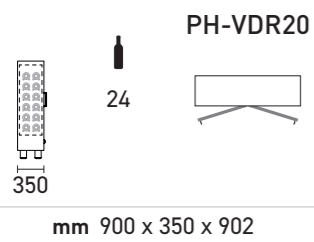

°C  
+4 / +18



°C  
+4 / +18

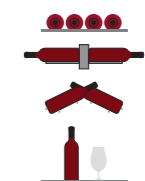

Allestimento interno personalizzabile  
Custom internal layout  
Aménagement intérieur personnalisable

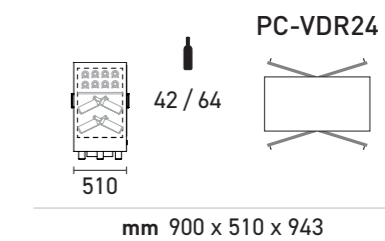
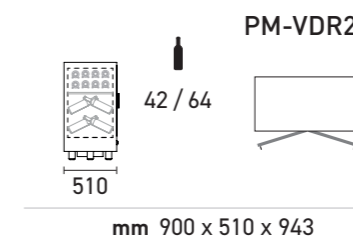
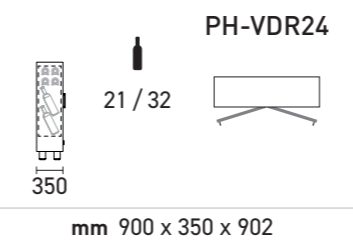
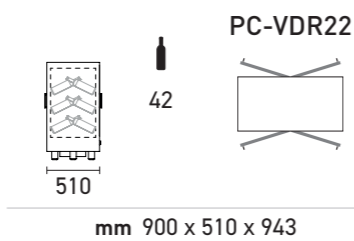
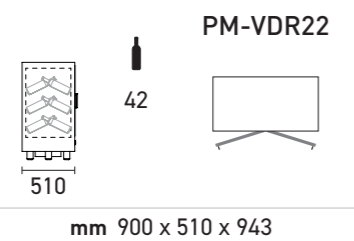

**MODULI NEUTRI - D**  
Neutral modules • Modules neutres



PH-MD10

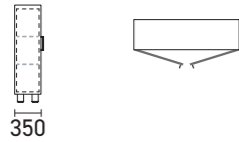

mm 900 x 350 x 902

PM-MD10

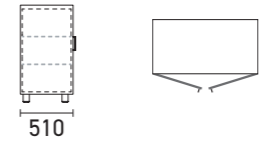

mm 900 x 510 x 943

PC-MD10

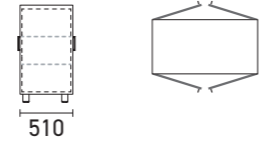

mm 900 x 510 x 943

PH-MD30

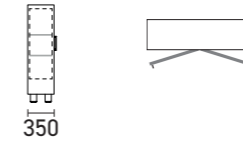

mm 900 x 350 x 902

PM-MD30

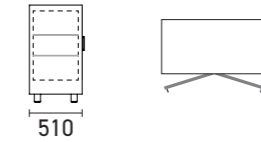

mm 900 x 510 x 943

PC-MD30

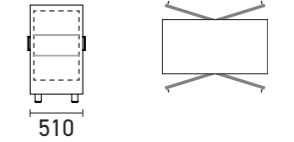

mm 900 x 510 x 943



Modulo realizzabile su misura da cm 20 a cm 90  
Custom made unit from cm. 20 up to cm. 90  
module sur mesure de cm. 20 jusqu'à cm. 90



PH-MD20

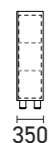

mm 900 x 350 x 902

PM-MD20

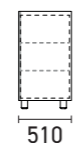

mm 900 x 510 x 943

PC-MD20

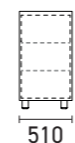

mm 900 x 510 x 943

PH-MD40



mm 486 x 350 x 902

PM-MD40

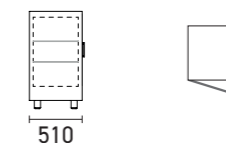

mm 486 x 510 x 943

PC-MD40

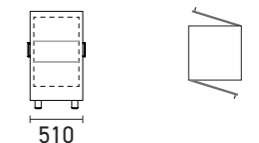

mm 486 x 510 x 943

# Finiture Parete Vino



## CORNICE LINEARE

Plain frame · Cadre linéaire



FN-CL

Colori disponibili

L01 - L10 - L11 - L20 - L21 - L22 - L23 - L40 - L50 - V01 - V02 - RAL

## CORNICE SAGOMATA

Moulded frame · Cadre mouluré



FN-CS

Colori disponibili

A01 - F01 - F02 - V01 - V02 - RAL

## PANNELLI LATERALI

Side panels · Les panneaux latéraux



FN-PL

L'inserimento dei pannelli laterali è da prevedere esclusivamente nell'installazione "da appoggio" oppure "centrale".

Side panels are to be added exclusively in the case of "wall-back" or "central" installations.

L'introduction des panneaux latéraux ne doit être envisagée qu'en cas de choix de l'installation "d'appui" ou "centrale".

Colori disponibili

M01 - L10 - L11 - L20 - L21 - L22 - L23 - L40 - L50 - V01 - V02 - RAL

## RIVESTIMENTO FIT

Fit cladding · Habillage Fit

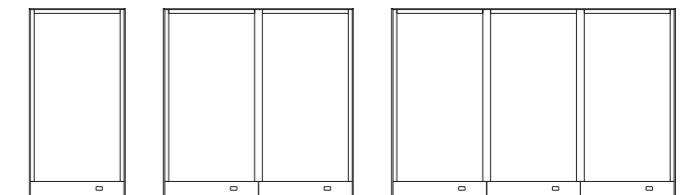

FN-RF\*1A

FN-RF\*2A

FN-RF\*3A

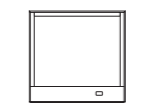

FN-RF\*1D

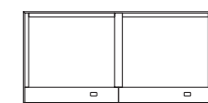

FN-RF\*2D

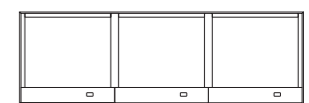

FN-RF\*3D

Rivestimento completo top, fianchi e frontalino.

Complete cladding for top, sides and front flap.

Rèvetement complet du top, côtés et panneau de base ouvrable.

Colori disponibili

L01 - L10 - L11 - L20 - L21 - L22 - L23 - L40 - L50 - V01 - V02 - RAL

# Parete Vino

Composizione ad incasso su cavalletto composta da due PM-VAR10.

Cornice sagomata finitura F01 (rivestimento in foglia oro patinato).

Built-in composition on stands made with two PM-VAR10.

Style frame in F01 finish (gold leaf coating).

Composition en retrait sur un socle composé de deux éléments PM-VAR10.

Finition avec cadre mouluré F01 (revêtement en feuille d'or patinée).

## COLORS (Pag. 170)





The Barlotti Concept  
Moscow – Russia



Diplomat  
Bucharest – Romania



Studio Senses  
Zwolle – Holland



Love It  
Milan Expo 2015 – Italy



Dempsey Cookhouse  
Singapore



Pasadena Restaurant  
Warsaw – Poland



Hippopotamus  
Macon – France



Dieta Oy  
Helsinki – Finland



Beim Abruzzebier  
Grosbous – Luxembourg



Kameha Grand Zurich  
Opfikon – Switzerland



Ambasciata del gusto  
Abbiategrasso – Italy



Krackwein by Götzelmann  
Bad Dürkheim – Germany



The Club at the Waterfront  
Bexhill - on - Sea – UK



The Local  
Lysaker – Norway



Korus  
Beirut – Lebanon



Le Montaigne Montparnasse  
Paris – France



One Apple  
Montecarlo – PT. Monaco



Carlton Restaurant  
Zurich – Switzerland



Weinhof Aufreiter & Landhaus Ilse  
Krems / Angern – Austria



Candando  
Luanda – Angola



Chokhi Dhani  
London – UK



Victorian restaurant  
Düsseldorf – Germany



Galerie CB  
Pretteln Bâlen – Switzerland

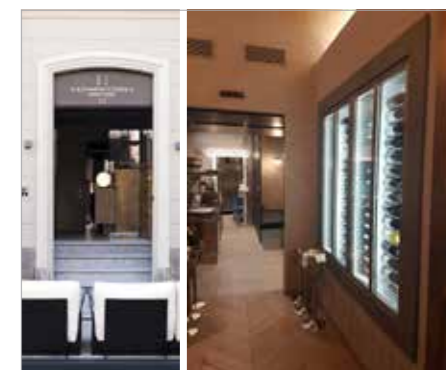

Bistrot Cannavacciolo  
Turin – Italy

# Parete Vino nel mondo

Model Reg. n. TO 2011/29 • Design Reg. n. TO 2012/41

Tecnologia, stile ed eleganza espressione del vero made in Italy.  
La Parete Vino, con le sue diverse forme e colori, arreda con classe importanti e prestigiosi hotel, ristoranti e residenze private, in tutto il mondo.

## Parete Vino around the world

Technology, style and elegance are expressions of the real "made in Italy". Parete Vino, with its many shapes and colours, decorates with class important and prestigious hotels, restaurants and private residences all over the world.

## Parete Vino dans le monde

La technologie, le style et l'élégance sont l'expression du vrai Made in Italy. Parete Vino, avec ses différentes formes et couleurs, décore avec distinction des importants et prestigieux hôtels, restaurants et résidences privées, dans le monde entier.



## Quadro Vino

Design e tecnologia si fondono per dar vita al primo quadro refrigerato mai realizzato al mondo. Un oggetto assolutamente innovativo, dal design raffinato, capace di rendere speciale ogni ambiente in cui è inserito.

*Design and technology combined to create the first refrigerated frame in the world. A greatly innovative article with sophisticated design that will make any location special.*

*Design et technologie ensemble pour créer le premier cadre réfrigéré jamais réalisé dans le monde. Un objet absolument innovant, design sophistiqué, capable de rendre spécial tout environnement dans lequel il est inséré.*

# I modelli

Models • Modèles



QV12



QV30



QV40



QV52

## COLORS (Pag. 170)

CORNICI • FRAMES • CADRES



PANNELLI • PANELS • PANNEAUX

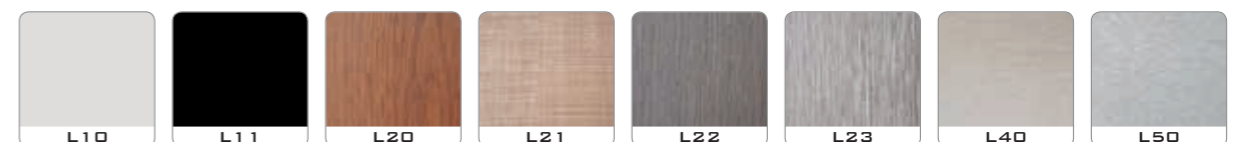

## Quadro Vino

Quadro Vino n. 40. Struttura bianca, pannello HPL bianco, cornice in colore RAL5012 (light blue).

Quadro Vino n.40. White structure, white HPL panel, frame in RAL5012 finish (light blue).

Quadro Vino n. 40 avec structure blanche, panneau en HPL blanc, cadre en couleur RAL5012 (bleu clair).



## Quadro Vino n. 12

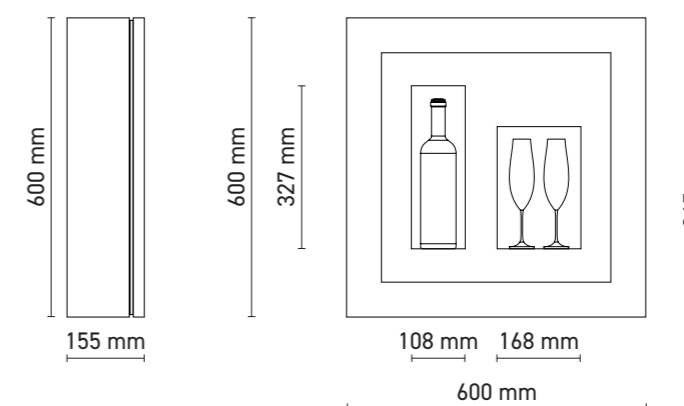

°C  
+ 4 / +10

Il Quadro Vino n. 12 è un espositore refrigerato per una bottiglia e due bicchieri. La minima profondità e l'installazione a parete ne consentono l'inserimento anche in spazi molto ridotti. È un oggetto studiato principalmente per la camera hotel ma straordinario in qualsiasi ambiente. Un'atmosfera unica e nuova che invita ad un brindisi veramente speciale.

*Quadro Vino n. 12 is a refrigerated display for one bottle and two glasses. Its reduced depth and wall installation make it suited even for small spaces. It is mainly designed for hotel rooms but extraordinary in any setting. A unique and new atmosphere that really calls for a very special toast.*

*Le Quadro Vino n. 12 est un présentoir réfrigéré pour une bouteille et deux verres. La profondeur réduite et la pose murale permettent de l'installer dans des lieux très réduits. Il est un objet conçu principalement pour la chambre d'hôtel, mais extraordinaire dans toutes les ambiances. Une atmosphère nouvelle et unique qui vous invite à porter un toast très spécial.*

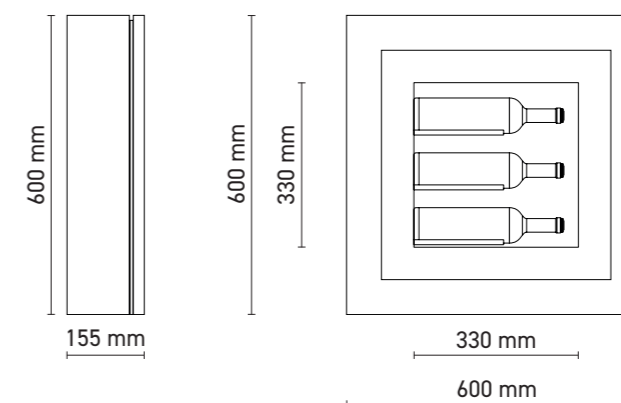

°C  
+ 8 / +20

## Quadro Vino n. 30

Il Quadro Vino n. 30 permette di esporre 3 bottiglie di spumante e mantenerle a giusta temperatura di servizio. Su questo modello è possibile scegliere l'opzione dell'esposizione in verticale delle bottiglie ideale per un servizio al bicchiere.

QUADRO VINO n. 30 allows you to display 3 bottles of sparkling wine and keep them at the right temperature. This model features a vertical bottle display option, ideal for service by the glass.

Le QUADRO VINO n. 30 vous permet d'exposer 3 bouteilles de vin mousseux et de les garder à la bonne température. Sur ce modèle, il est possible choisir l'option de l'exposition des bouteilles en vertical, idéal pour le service au verre.



QV40

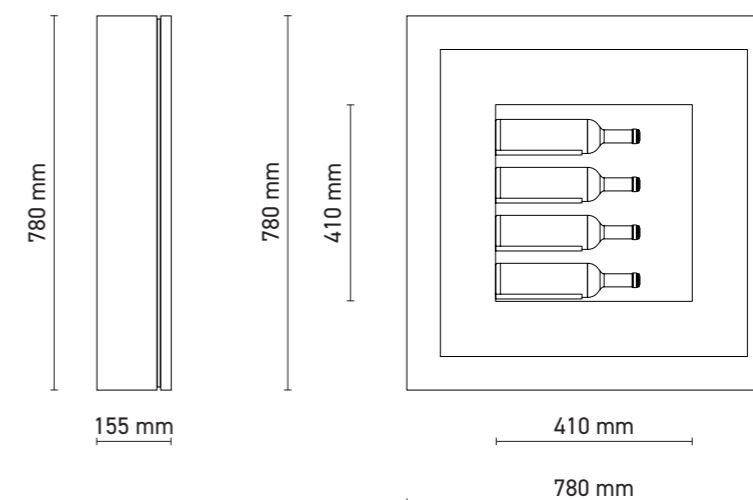

°C  
+ 12 / +20

## Quadro Vino n. 40

Il Quadro Vino n. 40 è un oggetto assolutamente innovativo, dal design raffinato, capace di rendere speciale qualsiasi ambiente. Trova facile inserimento nel ristorante e nell'hotel ma anche nelle residenze private. Su questo modello è possibile scegliere l'opzione dell'esposizione in verticale delle bottiglie ideale per un servizio al bicchiere.

*QUADRO VINO n. 40 is an innovative article with a sophisticated design which will make any setting special. It is suited for restaurants, hotels, and private homes alike. This model features a vertical bottle display option, ideal for service by the glass.*

*Le QUADRO VINO n. 40 est un objet totalement nouveau, design raffiné, capable de rendre tout ambiance spécial. Peut être installé dans le restaurant, l'hôtel ainsi que dans des résidences privées. Sur ce modèle, vous pouvez choisir l'option d'exposition des bouteilles en vertical, idéale pour le service vin au verre.*



QV52

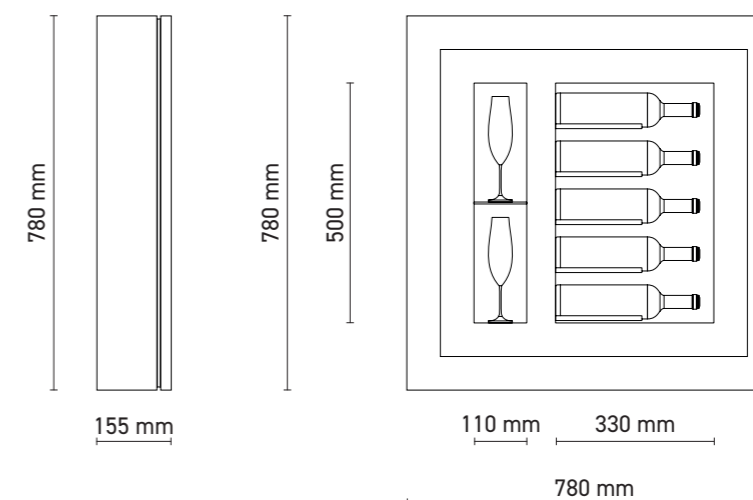

+ 12 / +20

## Quadro Vino n. 52

Il Quadro Vino n. 52 è un espositore climatizzato per cinque bottiglie e due bicchieri, un nuovo modo di esporre, conservare e servire il vino.

Aprire un quadro, prendere una bottiglia di vino e servirla ad una temperatura di 16 °C è un'azione assolutamente nuova che non avremmo mai pensato possibile.

È uno speciale complemento d'arredo che, inserito in cucina o nel salotto, piuttosto che nella sala di un ristorante o di un hotel, non può passare inosservato.

*QUADRO VINO n. 52 is a refrigerated display for five bottles and two glasses: a new way to display, store and serve wine.*

*Opening the frame, taking out a bottle of wine and serving it at a temperature of 16 °C is something we could have never imagined before.*

*A special element that - added to your kitchen and living room, or the dining room of a restaurant or a hotel - cannot go unnoticed.*

*Le QUADRO VINO n. 52 est une vitrine réfrigérée pour cinq bouteilles et deux verres, une nouvelle façon d'exposer, stocker et servir le vin.*

*Ouvrir un cadre du tableau, prendre une bouteille de vin et le servir à une température de 16 °C est une action totalement nouvelle que nous ne pensions pas possible.*

*Il est un détail de l'ameublement spécial qui, inséré dans la cuisine ou le salon, plutôt que dans la salle à manger d'un restaurant ou d'un hôtel, ne peut passer inaperçu.*

### ALLESTIMENTO BOTTIGLIE VERTICALI

Vertical bottles accomodation • Logement bouteilles en vertical

QV-OPT-BV



Sui modelli QV30 e QV40 è possibile richiedere l'optional allestimento bottiglie verticali. Durante la fase finale di costruzione vengono rimossi i tondini portabottiglie e sostituiti con degli appositi tappi affinché sia sempre possibile ripristinare l'allestimento standard con bottiglie orizzontali.

Con questa soluzione si può utilizzare il Quadro Vino anche per il servizio al bicchiere in quanto è possibile inserire e mantenere a giusta temperatura anche le bottiglie già aperte.

*Models QV30 and QV40 feature a vertical bottle fitting option. During the final phase of construction, support rods are removed and replaced with caps so that you can always restore the standard configuration with horizontal bottles.*

*With this solution you can use the QUADRO VINO for the service by the glass as you can set and maintain the right temperature even for open bottles.*

*Sur les modèles QV30 et QV40 il est possible avoir sur demande l'option de logement vertical des bouteilles. Pendant la phase finale de construction les tiges sont supprimés et remplacés par des bouchons appropriés de sorte que vous pouvez toujours restaurer la configuration standard avec des bouteilles horizontales.*

*Avec cette solution, vous pouvez utiliser le QUADRO VINO pour le service du vin au verre car vous pouvez saisir et de maintenir la bonne température, même les bouteilles ouvertes.*



Café collection